



200 SERIES

Capteura® 200 Series Non-Contact Displacement Sensing System

Capteura 200 Series

New ultra stable, low noise, non-contact capacitive displacement measurement system

- New 220-SL dual channel amplifier card with a 2U, 55.5 x 100 mm size
- New 208 and 216 electronic racks are three times smaller than the previous generation
- ESD protected inputs



Model 208 (8-channel rack) with (2) 220-S amplifier, (2) 220-SL amplifiers and (1) 200 C-DAQ clock card with USB data acquisition



Capteura® 200 Series modular 8-channel design versus legacy 8-channel system

- Better than 100,000:1 resolution (20nm) with HPC-150E-A-L2-1-B sensor, 200Hz bandwidth and 2.5mm range (double the range of competitive systems)

- 12KHz bandwidth option available

- Extremely long cable length with a capacitive load of 1500 pF

Lab and field testing has confirmed that the new **Capteura 200 Series** family has the industry best performance combining small sensor size and large displacement range with long cable lengths

200 Series Rack Specific tions

The **Capteura 200 Series** rack system combines two amplifiers into each card slot allowing it to be twice as dense as most systems. Its small size allows for a smaller rack than the previous generation. The **Capteura 200 Series** is available in three different form factors powered by either 90-240VAC or 9-36VDC power input.

The 208 rack has 4 card slots for up to 8 channels and the 216 rack has 8 card slots for up to 16 channels. The rear panel of the 208 and 216 racks hold a single-ended BNC connector for each primary analog output plus one or two secondary 25-pin D-Sub connectors providing single ended or differential analog output.

The 200-ENC enclosure has a single card slot. This configuration allows two channels in a compact standalone system. The Capteura 220-S-ENC and 220-SL-ENC include the 220-S or 220-SL amplifier card in the 200-ENC enclosure option.

Channels	Enclosure	220-S 220-SL	220-C	220-CP
2	200-ENC	1	-	1
2-8	208	1-4	1	-
10-16	216	5-8	1	-



Capteura® Model 200-ENC dual channel enclosure with 220-S amplifier card



Capteura® 208 and 216 multichannel rack systems

Capacitance Measurement Technology

Capacitance sensing is based on two conductive objects in close proximity, where the capacitance between objects varies with the gap. Typically, one object is grounded. The other is connected to a high-impedance amplifier that measures capacitance to ground by exciting it with a high-frequency current and measuring its voltage.

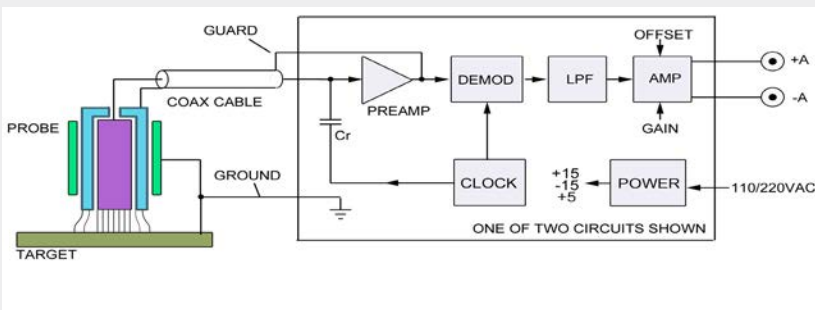

Capacitec supplies non-contact capacitive displacement probes to the Aerospace, Automotive, Coating/Printing/Photocopying, Extreme Environment, High Temperature/Cryogenic, and Power Generation markets worldwide.

Non-contact capacitive displacement and gap sensors are used in many critical applications like Aircraft Engine Rotor Eccentricity Realignment to maintain the perfect concentricity. This gap measurement is 0.075" (1.91mm) maximum with 20 feet of cable (6.10m).

Capacitec "V" series is the only family of catalogue parts for high temperature, non-contact displacement sensors with operation to 1600°F (870°C). The "V" series can also be exposed to a 2 tesla magnetic field along with 10⁷ RADS of radiation and extreme pressure.

System Specifications

The Capteura 200 Series multi-channel capacitive amplifier systems are configured according to user-specific needs and can be built in several different configurations.

- 200-ENC Single card enclosure
- 208-ACU 8 Channel AC rack
- 208-DCU 8 Channel DC rack
- 216-ACU 16 Channel AC rack
- 216-DCU 16 Channel DC rack
- 220-S Amplifier card
- 220-SL Amplifier card with LIN module
- 220-SQ Amplifier card with quadrature output
- 200-C Oscillator card
- 200-CP Oscillator module / DC power converter
- 200-L LIN module
- 200-DAQ DAQ card (requires separate 200-CP)

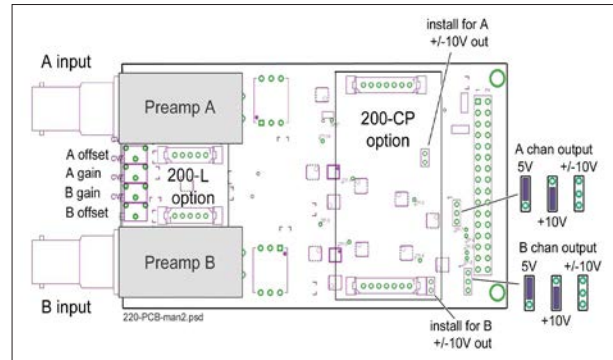

220 amplifier card shown with optional LIN and Oscillator modules. The LIN module allows a typical 0.2% linearity

Model 220 Amplifier Specifications

Size	3.94" x 2.15" x 0.75" (100mm x 55mm x 19mm)	
Bandwidth	200 Hz, 4 kHz, or 12 kHz frequencies (user specified)	
Range	Typically 2/3 sensor diameter	
Temperature Stability	80 ppm/°C temperature coefficient from 0 to 60°C	
Low Noise, High Resolution	0.1nm measurement, HPC-150E-A-L2-1-B, 250 µm range, 200Hz	
Linearity	Model 220-S	+/- 1% of full scale or better to 2/3 sensor diameter
	Model 220-SL	+/- 0.2% of full scale or better to 2/3 sensor diameter
ESD	20 kV electrostatic discharge to probe sensor, guard, or electronic rack	
Power Consumption	10W for 8 channels, 20W for 16 channels	
Input	BNC female connector	
Extension Cable	Cable length change of ≤10 foot (3.05m) affects the output by less than 0.2% FS	
Output	0-10 VDC, +/- 10 VDC, or 0-5VDC (specify for calibration). Optional USB digital output	
Output Type	Single-ended or differential outputs standard (specify for calibration)	
Quadrature Output	Model 200-SQ	For material density studies



220-S
Two-channel amplifier



220-SL
Two-channel amplifier with LIN modul



220-C
Oscillator card

Accessories

Optional Accessories

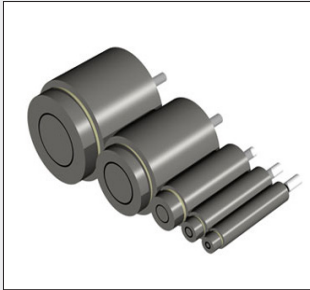

Capacitive Displacement Sensors
Full line of standard cylindrical, threaded and button sensors

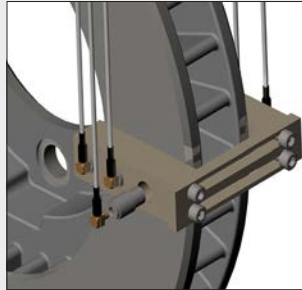

Disc Brake Wear Analysis Sensors
The model HPC-150C-H-IC-00 sensor assembly combines the benefits of small size and high temperature 750°F (400°C)



Calibration Stands
Calibration stands and micrometers

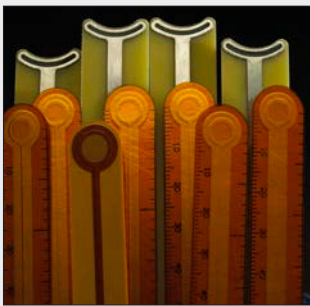

Thin Capacitive Probes
Standard models from .004" [0.1mm] thickness with .100" [2.54mm] linear range



Wand Holders
Wand holders with adjustable insertion length and slot guides.

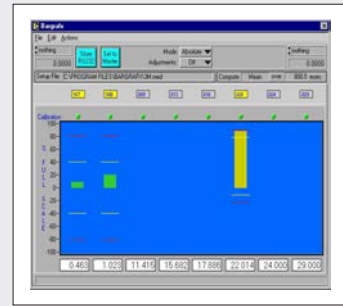

BargrafX™
LabView® based data acquisition, linearization and display software.



US HEADQUARTERS

Capacitec, Inc.
87 Fitchburg Road
P.O. Box 819
Ayer, Massachusetts 01432
USA
TEL: 978-772-6033
FAX: 978-772-6036
email: sales@capacitec.com
www.capacitec.com

EUROPEAN HEADQUARTERS

Capacitec Europe
16, rue Séjourné
94044 CRETEIL cedex
FRANCE
TEL: 33 1 43 39 48 68
FAX: 33 1 49 80 07 49
email: eurosales@capacitec.com
http://fr.capacitec.com