

NON-CONTACT DISPLACEMENT

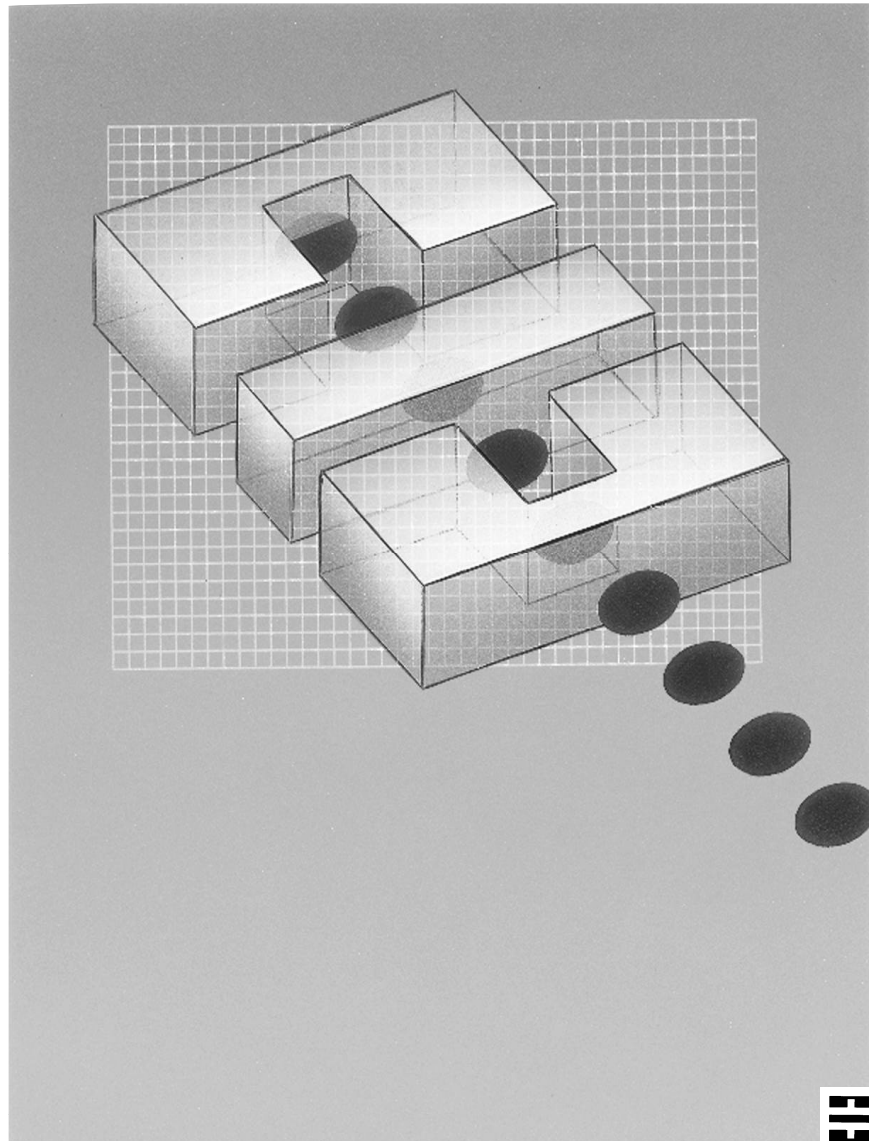

 **Capacitec**

S T A N D A R D P R O D U C T S

C A P A C I T E C

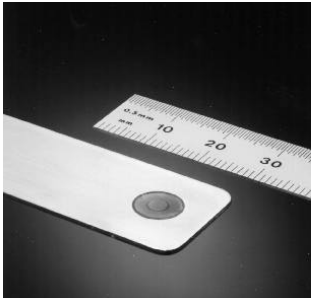

THIN GAPS

Engineers have long been searching for reliable and repeatable methods to measure thin gaps between 0.010" (0.254mm) and 0.125" (3.18mm). Mechanical contact methods such as feeler gauges, shims and calipers had long been the only available method to measure gaps, even in areas where damage could be caused to polished or sensitive surfaces. Capacitec has eliminated the requirement for the operator's "feel" inherent in feeler gauges by developing a broad line of non contact industrial gap sensors as well as a new portable gap measurement tool named GAPMAN®. These modern Capacitec non contact methods now provide engineers with excellent repeatability with the added ease of digitally stored data for use in today's advanced quality control systems.

MAJOR APPLICATIONS:

- Adhesive coatings
- Film manufacturing
- Plastic extrusions
- Automotive & Aircraft assembly
- Packaging materials
- Nuclear fuel rod gaps
- Photocopiers/Printing
- Tooling dimensions



HIGH TEMPERATURE

Significant scientific and engineering enhancements in advanced materials, Pre-and In-Process production methods and in-situ testing methods are driving the demand for displacement sensors that can handle extremely high temperatures up to 1832°F (1000°C). Contemporary producers of continuous flow steel, plate glass and plastics now use off-the-shelf high temperature Capacitec sensor solutions for in-process applications to control the quality of their production on a real time basis. Qualification testing of disc brakes, jet engine dynamics and high speed shaft rotations also rely on Capacitec sensors. Advanced materials for automobiles, structural components, and aircraft are also tested for strength and durability with the use of Capacitec's line of extensometers and clip gauges.

MAJOR APPLICATIONS:

- Disc brake testing
- Silicon Wafer processing
- Metal and Glass forming
- Jet engine thermal expansion
- Material strength testing
- Mold separation
- Turbine testing



EXTREME ENVIRONMENT

Maintaining the perfect alignment of a particle detector in a gap measuring only 0.050" (1.3mm), at 300°F (150°C) and in a chamber exposed to 2 tesla magnetic field along with 10⁷ RADS of radiation is not a job for your average displacement sensor. Fortunately, Capacitec is not a supplier of average displacement sensors - our sensors thrive in harsh environments. Capacitec model HPB sensors were indeed installed directly in the chamber of this particle accelerator at CERN where the sensors have performed flawlessly since the late 1980s. Another nasty sensor environment can be found inside a gas turbine engine rotating from 30k to 150k rpm. Here again Capacitec sensors sustain this challenging environment while taking critical blade tip clearance measurements at 1600°F (871°C).

MAJOR APPLICATIONS:

- Particle accelerators
- Linear inductive motors
- Diesel fuel injectors
- Gas turbine blade tip clearance
- Vibration measurements to 200 kHz
- Turbochargers
- High vacuum and Cryogenic Processes



NON INTRUSIVE ALIGNMENT

Microprocessor chips have found their way into a surprisingly high number of products that are around us every day in our home, car and office. This explosion in worldwide demand has forced semiconductor manufacturers to enhance quality and thru-put in ways never before imagined. Capacitec's microinch level positioning sensing systems assist chip processing and handling equipment manufacturers to sense silicon wafers for exact positioning prior to deposition, etching and other processing. This is accomplished without coming into contact or damaging their highly sensitive surfaces. Other industries where sensitive surfaces must be measured, damage free, are printing presses, photocopier rollers, computer hard disc drives and molten materials.

MAJOR APPLICATIONS:

- Silicon Wafer deposition & etching
- Silicon Wafer proximity
- Wafer cutting/processing
- Robot arm control
- Computer hard disc drives
- Printing Press/Photocopiers
- Tooling parallelism/alignment

CAPACITEC is a global technology company dedicated to advancing the capacitive principle of measurement physics to its highest level in sensor design. Our scientific and industrial customers depend on us for precision movement detectors, part-dimensional sizing, thin gap sensors and strain extensometry for material strength testing. Over twenty years of product line history has demonstrated Capacitec's strong support in all markets where a more sophisticated ruler is required and in areas where traditional sensors cannot fit or survive the environment.



Courtesy of DTC/UTDC

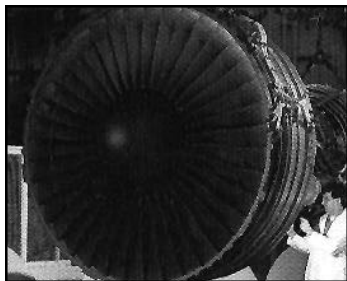

Courtesy of Pratt+Whitney Aircraft

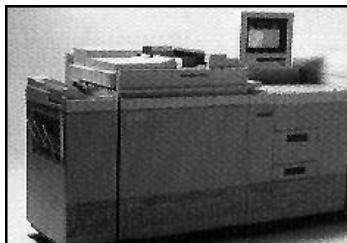

Courtesy of Xerox Corporation

A realized claim of extremely high sensitivity to minute physical/mechanical changes and exceptional amplifier output stability support capacitive sensor applications especially in severe environments of temperature, magnetic fields, high radiation and non-contact, non-intrusive applications. An aggressive research and development program continues to drive Capacitec's advances in instrumentation, digital circuitry and demonstrated longevity in rugged packaging design. These investments combined with updated manufacturing techniques enable us to consistently provide products of superior performance, stability and economy of packaging and pricing.



Capacitec GAPMAN®



STANDARD PROBES

Capacitex non-contact displacement probes are noted for their large linear range versus the small outside diameter of the probe package.

HPB SERIES BUTTON PROBES

A tremendous advantage in measuring displacement and part dimensional changes can be gained by use of thin "side-looking" Capacitex® button probes. Their forte is in thin gap inspection and tolerances measured inboard and hidden in difficult to investigate products. They are often used in pairs to compensate for part misalignment and gage positioning. HPB Series probes exemplify the premier strengths of capacitive sensors to provide absolute accuracy of 0.000010" (0.25 microns) and better than 1×10^{-7} " (0.0025 microns) resolution. The HPB probes are provided without any case as standard. If installation of these probes in a metallic case is planned, an optional -D (250°C epoxy) dip coating protection is required. Capacitex specializes in custom configurations along with probe installation services in customer components and fixtures. Please consult the factory.

BUTTON SERIES

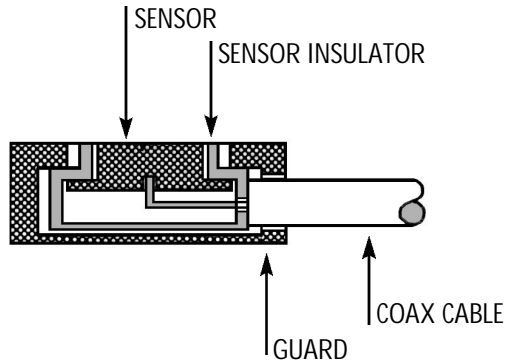
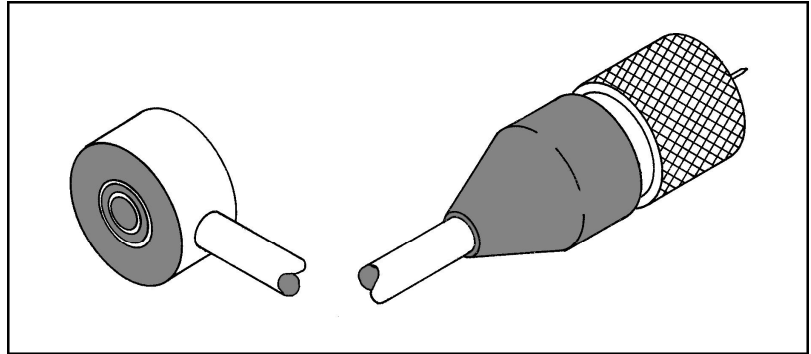

● Range specified in inches (millimeters)
Encased range implies a probe face flush mounted to an earth grounded surface (Consult Factory)

For thinner gap sensors ask for information on Capacitex's HPS Series of flat sensors 0.0098" (0.25mm) thick typical

HPB-40	HPB-75	HPB-150	HPB-375	HPB-500
SENSOR OD: 0.040 (1.016)	SENSOR OD: 0.075 (1.905)	SENSOR OD: 0.150 (3.810)	SENSOR OD: 0.375 (9.525)	SENSOR OD: 0.500 (12.70)
GUARD OD: 0.156 (3.962)	GUARD OD: 0.220 (5.588)	GUARD OD: 0.315 (8.00)	GUARD OD: 0.670 (17.02)	GUARD OD: 0.920 (23.37)
LINEAR RANGE: 0.020 (0.508)	LINEAR RANGE: 0.050 (1.270)	LINEAR RANGE: 0.100 (2.540)	LINEAR RANGE: 0.250 (6.350)	LINEAR RANGE: 0.325 (8.255)
ENCASED RANGE: 0.015 (0.381)	ENCASED RANGE: 0.037 (0.940)	ENCASED RANGE: 0.075 (1.905)	ENCASED RANGE: 0.187 (4.750)	ENCASED RANGE: 0.244 (6.20)

STANDARD PROBES

Capacitec non-contact displacement probes are noted for their large linear range versus the small outside diameter of the probe package.

HPC SERIES CYLINDRICAL PROBES



The cylindrical probes are the most popular version of the non-contact series. Its case is an additional component added to the sensor and guard elements to avoid being earth grounded. A set screw or split clamp housing is normally designed to hold it in place for easy adjustments.

NOTES:

1. The guard element is driven with an electronic voltage 2 to 20 Volts P - P maximum and must not be grounded.
2. -D dip coatings also prevent the driver, sensor and guard elements from being accidentally earth grounded or shorted. (not available on "V" and "S" series probes)
3. Range values tested with 5 ft. (1.524 meters) of Capacitec L2 cable.
4. Range and signal to noise ratio will be degraded by longer cable lengths.

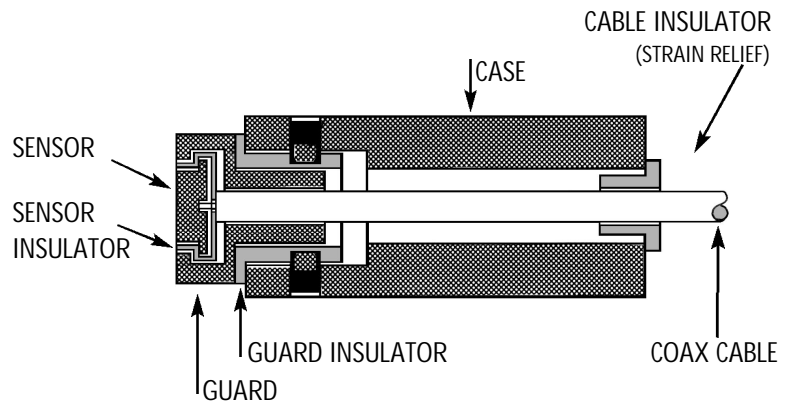
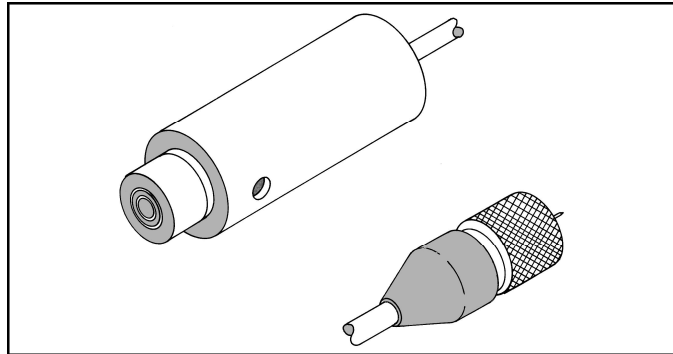
CYLINDRICAL SERIES

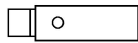
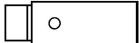

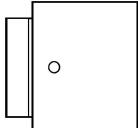
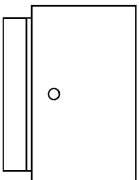
HPC-40	HPC-75	HPC-150	HPC-375	HPC-500
				
SENSOR OD: 0.040 (1.016)	SENSOR OD: 0.075 (1.905)	SENSOR OD: 0.150 (3.810)	SENSOR OD: 0.375 (9.525)	SENSOR OD: 0.500 (12.70)
CASE OD: 0.187 (4.750)	CASE OD: 0.250 (6.350)	CASE OD: 0.375 (9.525)	CASE OD: 0.750 (19.05)	CASE OD: 1.000 (25.40)
LINEAR RANGE: 0.020 (0.508)	LINEAR RANGE: 0.050 (1.270)	LINEAR RANGE: 0.100 (2.540)	LINEAR RANGE: 0.250 (6.350)	LINEAR RANGE: 0.325 (8.255)
MAX. RANGE: 0.040 (1.016)	MAX. RANGE: 0.075 (1.905)	MAX. RANGE: 0.150 (3.810)	MAX. RANGE: 0.375 (9.525)	MAX. RANGE: 0.500 (12.70)

 Range specified in inches (millimeters)
Consult the Factory for complete specifications on calibrations and performance.

STANDARD PROBES

Capacitance non-contact displacement probes are noted for their large linear range versus the small outside diameter of the probe package.

HPT SERIES THREADED PROBES



Similar to the HPC Series the threaded probes allow mounting into a drill and tapped hole or bracket where more limited access is available. The probe is held in place with a mating nut (optional) and may be rotated for fine axial positioning.

NOTES:(cont')

5. A 20 point archived calibration record of voltage output versus nominal displacement is provided standard with every probe.
6. Sensor must be calibrated with final length of cable for stated results.
7. All components are electronically isolated from each other by greater than 20 megohms of leakage resistance (at room temperature) for best operation with the instrumentation.

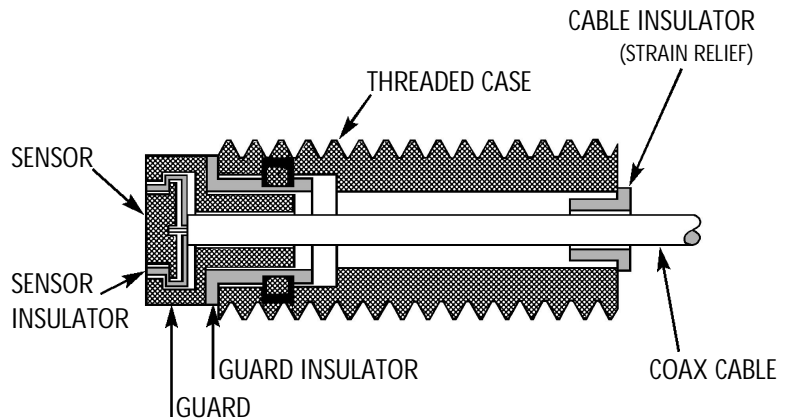
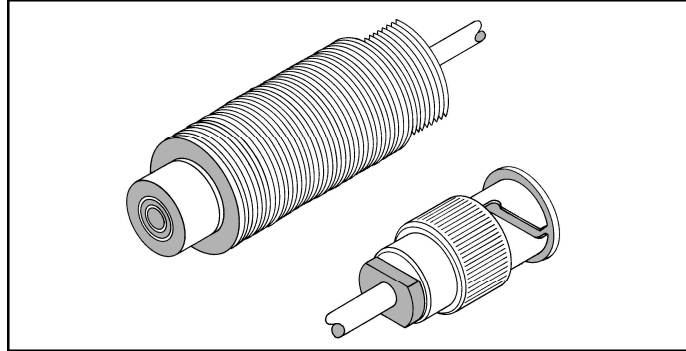
THREADED SERIES

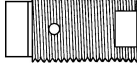
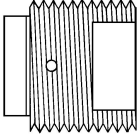
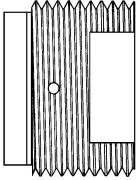

HPT-40	HPT-75	HPT-150	HPT-375	HPT-500
				
SENSOR OD: 0.040 (1.016)	SENSOR OD: 0.075 (1.905)	SENSOR OD: 0.150 (3.810)	SENSOR OD: 0.375 (9.525)	SENSOR OD: 0.500 (12.70)
CASE OD: 0.187 (4.750)	CASE OD: 0.250 (6.350)	CASE OD: 0.375 (9.525)	CASE OD: 0.750 (19.05)	CASE OD: 1.000 (25.40)
LINEAR RANGE: 0.020 (0.508)	LINEAR RANGE: 0.050 (1.270)	LINEAR RANGE: 0.100 (2.540)	LINEAR RANGE: 0.250 (6.350)	LINEAR RANGE: 0.325 (8.255)
THREAD SIZE: 10 - 32 UNF	THREAD SIZE: 1/4 - 28 UNF	THREAD SIZE: 3/8 - 24 UNF	THREAD SIZE: 3/4 - 16 UNF	THREAD SIZE: 1 - 12 UNF

 Range specified in inches (millimeters)
Thread size defined as first number = diameter (3/8); second number threads per inch (24)
Optional metric sizes available (Consult Factory)

GAP MEASURING PROBES

HPB Series Industrial Wands

Our Model HPB series button-like capacitive sensors are manufactured in a very thin version and installed "back to back" in a rigid or semi rigid 1mm nominal industrial wand. The purpose of the wand is to replace hard stop gauge blocks with an electronic equivalent that will withstand the industrial environment. This series is custom designed to meet customer specifications both in size as well as operating temperatures to as high as 400°F (200°C) optional. Model 2HPB-5 dual wand has a linear measurement range of 0.100" (2.5mm). This design allows position compensated linear gap measurement throughout the range. The HPS series is manufactured in custom lengths up to 79" (2.0m).

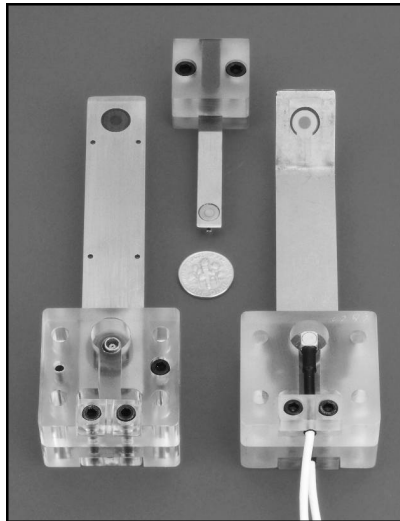

HPB Series Industrial Wands

GAPMAN®

Portable Electronic Feeler Gage

GAPMAN is the world's first high precision, non-contact, portable electronic gap measurement gage. It features a dual capacitive sensor for position-compensated measurement and easy insertion into very narrow gaps down to 0.009" (0.22mm) in a wide range of parallel and roller gap applications. Microprocessor based and application software driven, GAPMAN records and stores data points for easy transfer to SPC and other quality systems. Additional information is available.



Gapman Kit

GPD Series GAPMAN Wands

The GAPMAN is equipped with a patented GPD series quick-change probe (as shown below). GPD probes are like the HPD sensors, but with both interface connection on the same



side to conveniently connect to our patented contacts. The GPD-5F-A-200 model is our standard GAPMAN probe. Its dimensions are 0.016" (0.4mm) thick by 8.0" (200mm) long. An optional thinner choice would be the GPD-5G-A-150 which is 0.009" (0.22mm) thick and 6.0" (150mm) long. Both these probes are very flexible and their prolonged length allow good penetration into "inboard" and hard to reach gap locations.



HPS SERIES PROBES

The single sided very thin stick-on HPS sensors provide the thinnest packaged capacitive sensor elements available in the market today. Several sizes available from stock which include lengths up to 8.0" (200mm) with a thickness as low as 0.004" (0.11mm). Our proprietary snap-on connector provides a convenient but robust connection. The linear measurement range of a typical HPS-4 series sensor is 0.100" (2.5mm) nominal in a 0.394" (10.0mm) overall width.

The HPD is a dual sided version of the HPS with approximately double the thickness (0.016"/0.4mm standard).

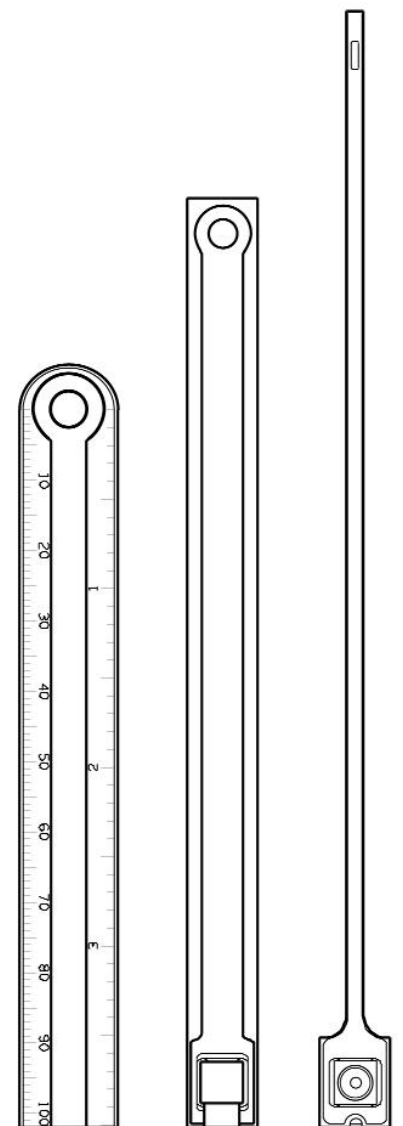

GPD-5

HPD-4

HPS Custom

(Shown Actual Size)

ELECTRONIC RACKS

4000 SERIES

The Series 4000 Capacitec® amplifiers and racks were designed to offer the best signal to noise ratio and wide band width response options in a simple modular package. The 4000 Series was built upon our 20 year proven foundation of 3000 Series amplifiers (3101-SP, 3200, 3201-SP) still in operation. Utilization of individual pins in a 32 pin DIN connector increases reliability for more industrial applications where vibrations are present. The small Euro-style 2U size boards have appeal for small portable packaging as well as high (but lightweight) density applications. When coupled with Capacitec® non-contact displacement probes, they produce a linear output voltage proportional to the gap spacing between the probe and a ground plane. The systems are designed to produce stable and reliable operation with excellent gain and zero shift stability with respect to changes in ambient temperature. Stability is achieved with a digitally derived sine-wave oscillator, having a crystal clock as the frequency reference.



OTHER FEATURES

Other special features include synchronous detection, low drift operational amplifiers and a modular preamplifier (PC-201B) and power supply (standard). The units also have an optional linearization board to improve performance by a factor of ten from $\pm 2\%$ to $\pm 0.2\%$ linearity with no outside computer compensated curve fitting and without sacrificing frequency response (to 5kHz down 3dB). The amplifiers are designed to operate with every probe configuration and all sensitivity ranges by simple recalibration without internal part changes.

4000 SERIES RACKS

4016-P115: 16 Channel (with 4100-S or 4100-SL) 19 inch rack enclosure with an additional slot for a 4100-C clock driver card. A $\pm 15\text{VDC}$ regulated power supply at 850mA is standard to power this unit. (A linear type is preferred for highest signal to noise performance). The unit has individual 0-10VDC analog outputs as well as three input/outputs on two mass terminated Centronics style connectors for computer or data acquisition interface and option cards. An internal AC power supply is available standard by signifying -P115, -P220 or -P240 (AC).

4008-P115: 8 Channel (with 4100-S or 4100-SL) rack enclosure approximately half the size of the 4016 with the same standard features. A $\pm 15\text{VDC}$ regulated power supply at 500mA is standard to power this unit.

4004-P115: 4 Channel (with 4100-S or 4100-SL) rack enclosure approximately 5 inches wide with the same standard features but with a 24 pin phone connector. A $\pm 15\text{VDC}$ regulated power supply at 350mA is standard to power this unit.

Typical 4004 Package

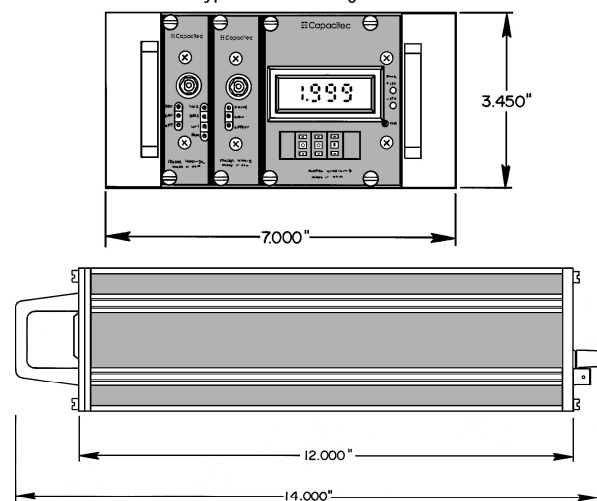

● All 4000 Series racks and amplifiers combinations are  Rated which includes the New Low Voltage Directive.

AMPLIFIERS CARDS & ACCESSORIES

4100 SERIES AMPLIFIERS

4100-S: A basic single channel amplifier card with a 1.0 inch rack mountable front panel. A screwdriver implemented offset and gain control is available and offers $\pm 2\%$ of full scale typical linearity with 0.01% repeatability. It is ideally suited for OEM and high volume, multi-point applications where computer interface and possible linearization is available. (1 slot rack requirement).

4100-SL: The same as the 4100-S except that an add-on linearization board gives the basic amplifier an enhanced stand alone linearity of $\pm 0.2\%$ accuracy of full scale using only screwdriver adjustable pots (1 slot rack requirement).

4100-L: Same as the 4100 except that the optional linearization board has been added to yield the same performance as the 4100-SL card but with the convenience of the large adjustment dials. $\pm 0.2\%$ linearity and 0.01% repeatability of full scale are typical. (2 slot rack requirement)

4100-B: A one inch wide blank panel is available to cover any empty slots to prevent damage to internal parts due to dust, dirt and accidental factors.

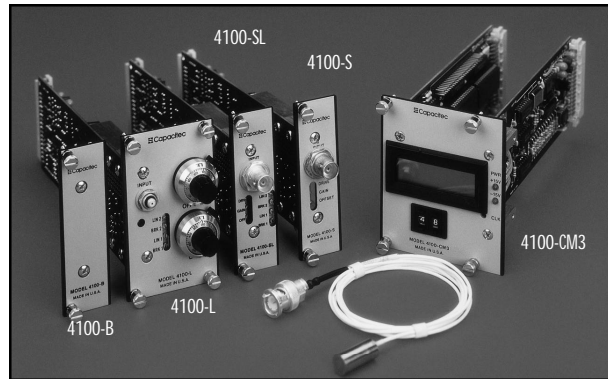

410 SERIES

The 410 series is packaged as a self contained unit including a clock card and signal conditioning electronics. The compact package runs on $\pm 15\text{VDC}$ and the features are the same as the 4000 series, except for linearity which is 1% full scale. The 410 electronics are also available unpackaged for OEM applications or when used in conjunction with other customer instrumentation configurations.

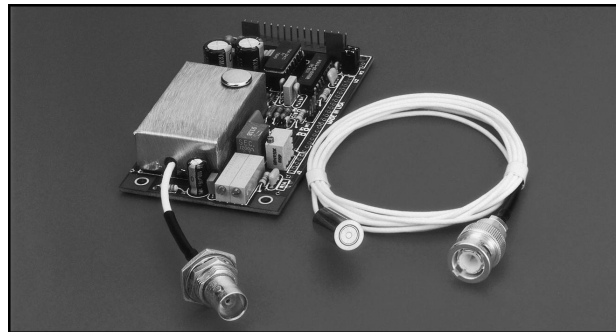

410 Series

4100 SERIES CLOCK DRIVER CARDS

4100-C: A separate clock driver card is required to drive 1 or more amplifier cards. This unit indicates the "on" condition of the ± 15 volts DC supply voltage with individual red LED lights and has a x3 amplitude drive adjustment pot for supplying a 15kHz excitation signal. This control is used to match a required calibration sensitivity to a specific model displacement probe. (1 clock, 0.80" wide normally fits in a far right rack slot).

4100-CM3-3.5 LED: The same as the 4100-C, except that a larger, 2.8" inch wide, front panel has been added to accommodate a standard 3 1/2 digit LED meter with a multi channel selector switch. An optional 4 1/2 digit LED meter may be specified. The meter normally reads percent of full scale (i.e. 100.0) or can optionally read in volts DC (i.e. 10.00). (2 slots plus a clock card slot.)

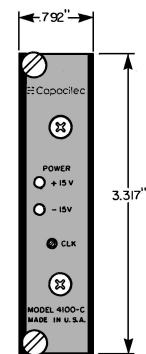

4100-C



NOTE:

- Instrumentation amplifiers come standard with 232Hz, -3dB frequency response with 18dB/octave roll-off. Specify options: -WB with 3.1kHz, -3dB or -5WB with 5.0kHz, -3dB.

An additional x1 to x6 screwdriver adjustable amplitude control is provided standard on 4100-S, SL, and -L to have a total of 3 x 6 = 18 V P-P drive amplitude capability.

Model 4100-SL and -L amplifiers have A + B / A - B sums amplifier standard. Consult factory.

All LED meters require racks with the -5V option. Other accessory cards available. Consult factory.

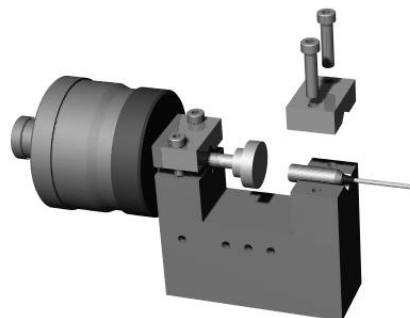

CS-1 Calibration Stand

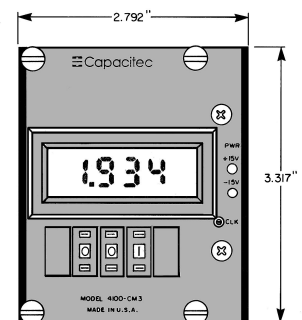

4100-CM3-3.5 LED

6100 SERIES 200kHz AMPLIFIERS

6100 SERIES 200kHz FREQUENCY RESPONSE

The 6100 Blade Tip Clearance Measurement System is a powerful tool for measurement of rapidly spinning or vibrating targets in high temperature environments up to 1832°F (1000°C). The high temperature functionality of the 6100's CM/DM series probes combines with a conditioned frequency response capability to 128kHz to make the system uniquely suited for any measurement application in which a fast response is required such as blade tip clearance in rotating turbines, turbochargers and jet engines. Other fast moving but non-continuous parts like hydroelectric generators as well as high frequency vibration or modal analysis of continuous targets are other typical applications.

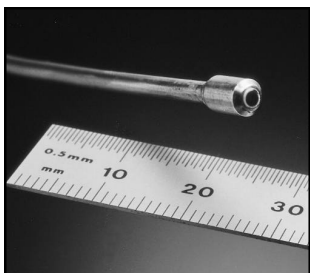

The 6100-SC amplifier provides a digitized output that is acquired by the 6100-DSP card which then performs signal processing that results in a linear output at up to 128kHz. (The 6100-SC can also provide a raw analog output up to 200kHz which can be separately accessed by the user at the module's OBNC port.)

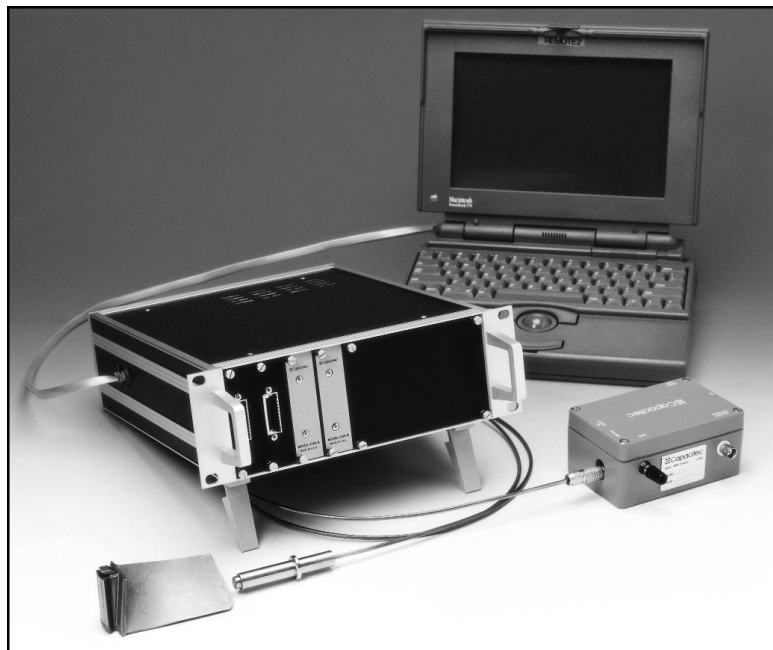

The Model 6100 offers a range of blade tip clearance outputs which are user configurable via the available control software. For high speed vibration applications which cannot utilize the 6100-DSP firmware's temperature compensation, model DM series probes provide improved DC stability over a temperature range to 1100°F (600°C) with maximum operating temperature to 1832°F

(1000°C). The high temperature CM and DM Series probes and cables provide operation to 1832°F (1000°C). The outer shields of the CM and DM Series probes are at earth ground potential to prevent electrical shorts and to facilitate ease of installation in tight routing locations.

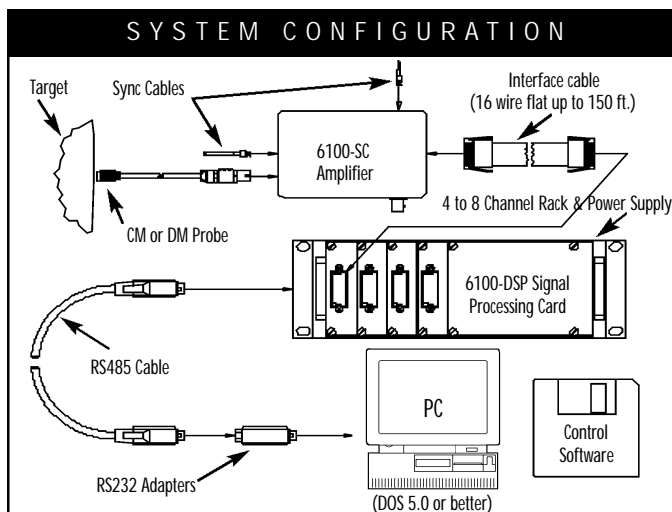

MODEL 6100 SPECIFICATIONS :

Typical target size: same as sensor OD or larger

Frequency response: 2Hz-128kHz (-3dB), conditioned DC-200kHz raw analog optional

Measurement range: 0.010" to 0.197" (0.254mm - 5.0mm); based on probe size

Linearity: $\pm 2\%$ /half F.S. with signal conditioning

Repeatability: $\pm 0.5\%$ F.S.

Probe Size: 0.156" to 0.750" (3.96mm-19.05mm) OD

Probe operating environment: Dry, (non-condensing), 32-1832°F (0-1000°C)

Cable OD: 5U cable, 0.125" (3.18mm); 5U+ cable, 0.137" (3.48mm)

Cable length: 3 meters max length with earth grounded shield

Power requirement: +5VDC @350mA; ± 15 VDC @ ± 50 mA provided by 4000 series rack

• A single channel configuration of a Model 6100 Blade Tip Clearance Measurement System is comprised of a 6100-DSP signal processing card, a 6100-SC amplifier unit, a CM or DM series probe, cables and control software.

PROBE ORDERING FORMAT

HPX	-XXX	X	-X	-XX	-XX	-X
Shape	Sensor Diameter	Probe Length	Operating Temperature	Cable Type	Cable Length	Connector Type
C: Cylindrical	“Thousandths”	A: 0.500” (12.7)	A: 32 to 300°F	L2: .093 (2.4)	In feet	M: 10-32
B: Button	of an inch	B: 0.625” (15.9)	(0 to 150°C)	L3: .063 (1.6)	(about 0.3m)	Microdot
T: Threaded	(.0254)	C: 0.750” (19.1)	E: -100 to 400°F	I2: .125 (3.2)		
R: Rectangular		D: 0.875” (22.2)	(-73 to 205°C)	N: .125 (3.2)		
S: Flat		E: 1.000” (25.4)	V: -100 to 1600°F	ND: .165 (4.2)		B: BNC
D: Dual Flat		F: 1.250” (31.7)	(-73 to 871°C)	T: .063 (1.6)		FX: MCX FEMALE
		G: 1.500” (38.1)	S: -100 to 1832°F			MX: MCX MALE
		H: 1.750” (44.5)	(-73 to 1000°C)			
		I: 2.000” (50.8)				

EXAMPLE (1) : HPC-150X-A-L2-5-B

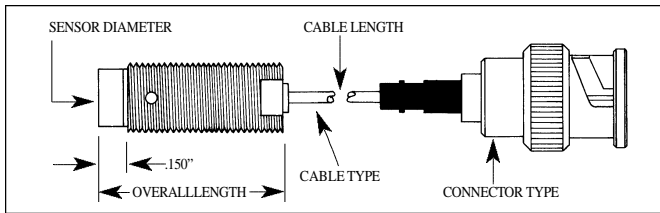

EXAMPLE (2) : HPB-75X-E-L3-5-M

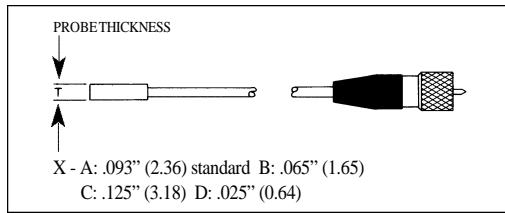

SPECIFICATIONS & PROBE ORDERING NOTES

DIMENSIONS: All dimensions are shown as typical only. Please contact the factory for exact dimensions.

MAXIMUM RANGE: Same as the diameter of the sensor element. (Minimum range is touch or 0.1% of full scale.)

LINEAR RANGE: Two thirds (0.67) times the sensor diameter typical.

PROBE INTERCHANGEABILITY: ±10% of full scale maximum change, ±2% typical.

PROBE MATERIAL COMPOSITION: A and E, stainless 303; V, Inconel 600, other materials available.

CALIBRATIONS: There are 21 numbered, standard calibrations available, please consult factory and specify when ordering.

RANGE:

- Standard listed ranges are ratios from 0-10.000VDC analog output, but each probe may be calibrated with several range versus sensitivity calibrations. Calibration sensitivity from 0.001VDC/0.001”(0.0254mm) to 10.000VDC/0.001”(0.0254mm) are available.
- Range is defined as from touch to full scale reading, ±50% of range = ±10.000VDC calibration optional.

GROUNDING: “-D” dip coatings are available to prevent the electronically driven sensor/guard elements from being accidentally earth grounded and shorted.

EXTENSION CABLES: Many extension cables are available depending upon connector types. Consult factory for proper part numbers. Example: EC-D-L2-5 is a standard 5 foot extension cable with female BNC to male BNC connectors.

CABLE SPECIFICATIONS

Cable Temperature Range for “A” & “E” Probes, -65°F to 446°F (-54°C to 230°C)

Type L2	OD .093” (2.4)	Teflon	~ 30 pF/ft (90/m)
---------	----------------	--------	-------------------

Type L3	OD .063” (1.6)	Teflon	~ 26 pF/ft (78/m)
---------	----------------	--------	-------------------

Type I2	OD .125” (3.2)	Teflon	~ 14 pF/ft (42/m)
---------	----------------	--------	-------------------

Cable Temperature Range for “V” Probes, -98°F to 1600°F (-72°C to 870°C)

Type T	OD .063” (1.6)	Semi-rigid Inconel 600 powder filled	~ 60 pF/ft (180/m)
--------	----------------	--------------------------------------	--------------------

Type N	OD .142” (3.6)	Flexible Inconel Braided	~ 20 pF/ft (60/m)
--------	----------------	--------------------------	-------------------

Type ND	OD .165” (4.2)	Low Impedance Shield Version of N	~ 35 pF/ft (105/m)
---------	----------------	-----------------------------------	--------------------

CABLE TYPE: 99.9% shielded low noise coaxial with driven braided shield (maximum potential 20 volts P-P), 5 feet (1.5m) standard. 2000pF maximum probe capacitive load.

TYPICAL APPLICATIONS

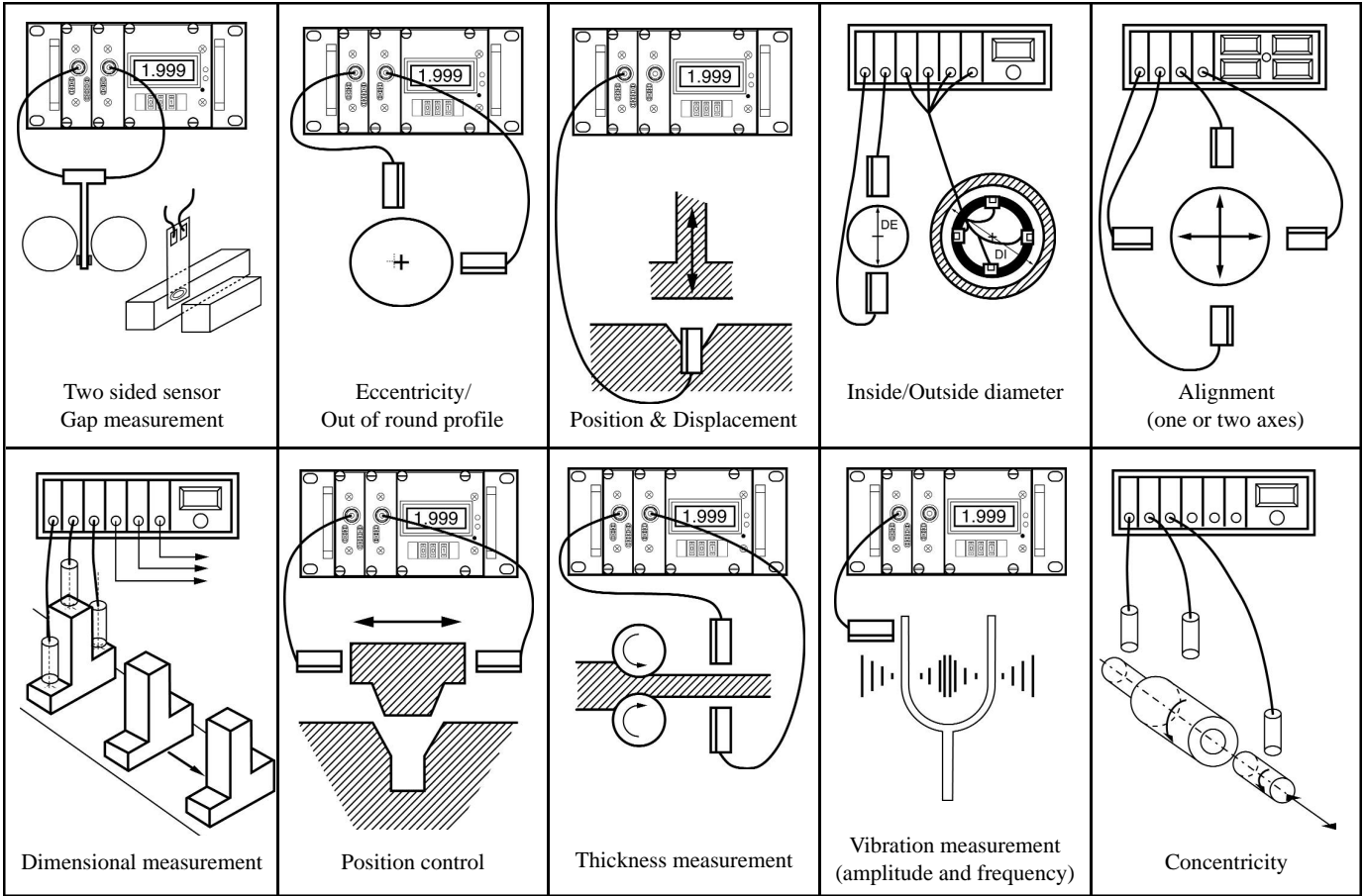

 **Capacitec**

P.O. Box 819
87 Fitchburg Road
Ayer, MA 01432 USA
978-772-6033
FAX: 978-772-6036

Capacitec sarl
16, rue Séjourné
94044 CRETEIL cedex
FRANCE
33 1 43 39 48 68
FAX: 33 1 49 80 07 49